



OCPP EV Charger Installation Manual

WWW.BENYI.COM



Order Your Style



ZHEJIANG BENYI NEW ENERGY CO.,LTD.

WENZHOU BRIDGE INDUSTRIAL ZONE, BEIBAIXIANG TOWN, ZHEJIANG, CHINA

TEL: +86-577-5717 7008 FAX: +86-577-5717 7007

VERSION: 20230805

✉ benyi@zjbenyi.com

🌐 www.benyi.com

♻️ This catalogue has been printed on ecological paper.

© Zhejiang Benyi New Energy Co.,Ltd.all rights reserved.

⚠️ If the models and specification in this product catalogue is changed due to the change of products, we will not inform.





G R E E N S M A R T

CONTENTS

1. Safety Information 01

- Important safety instructions P-01

2. Product Introduction 03

- 2.1. Product Appearance P-03
- 2.2. Parameter table P-04
- 2.3. Features P-05
- 2.4. Protection Functions P-07

3. Installation Instructions 09

- 3.1. Installation Considerations P-09
- 3.2. Minimum Installation Requirements P-09
- 3.3. Position P-10
- 3.4. Height P-10
- 3.5. Power Supply P-10
- 3.6. Accessories List P-11
- 3.7. Installation Step P-12
- 3.8. SIM Card Installation P-20

4. Operating instructions 21

- 4.1. Buttons On harger P-21
- 4.2. Buzzer P-22
- 4.3. Dynamic Load Balancing Kit P-22
- 4.4. LED Lights Display P-23
- 4.5. Firmware Update via OCPP Server P-27

5. Warranty 28











6. Manufacturer self-declaration 28

1. Safety Information



Important Safety Instructions

This document contains important instructions and warnings that must be followed when installing and maintaining the EV Charger.





Warning

-  Read this entire mandatory document before installing or using the EV charger.
-  This device should be supervised when used around children.
-  The BCP series EV Charger must be grounded through a permanent wiring system or an equipment grounding conductor.
-  Do not install or use the EV Charger near flammable, explosive, harsh, or combustible materials, chemicals, or vapors.
-  Use the EV Charger only within the specified operating parameters.
-  Never spray water or any other liquid directly at the wall mounted EV Charger. Never spray any liquid onto the charger handle or submerge the charger handle in liquid. Store the charger handle above the ground to prevent unnecessary exposure to contamination or moisture.
-  Stop using and do not use the EV Charger if it is defective, appears cracked, frayed, broken, or otherwise damaged, or fails to operate, or continue operation.
-  Do not attempt to disassemble, repair, tamper with, or modify the EV Charger. The EV Charger is not user serviceable. Contact us for any repairs or modification.
-  Transporting the EV Charger, handle with care. Do not subject it to strong force or impact or pull, twist, tangle, drag, or step on the EV Charger, to prevent damage to it or any components.
-  Do not touch the EV Charger's end terminals with sharp metallic objects, such as wire, tools, or needles.
-  Do not forcefully fold or apply pressure to any part of the EV Charger or damage it with sharp objects.

1. Safety Information

-  Do not insert foreign objects into any part of the EV Charger.
-  Use of the EV Charger may affect or impair the operation of any medical or implantable electronic devices, such as an implantable cardiac pacemaker or an implantable cardioverter defibrillator. Check with your electronic device manufacturer concerning the effects that charging may have on such electronic devices before using the EV Charger.

Cautions

-  Do not use private power generators as a power source for charging.
-  Incorrect installation and testing of the EV Charger could potentially damage either the vehicle's Battery and/or the EV Charger itself. Any resulting damage is excluded from New Vehicle Limited Warranty and the EV Charger Limited Warranty.
-  Do not operate the EV Charger in temperatures outside its operating range of -25°C to +55°C.
-  That adaptors or conversion adapters are not addowed to be used.
-  That cord extension sets are not allowed to be used.

Notes

- Ensure that the EV Charger's charging cable is positioned so it will not be stepped on, driven over, tripped on, or subjected to damage or stress.
- Do not use cleaning solvents to clean any of the EV Charger's components. The outside of the EV Charger, the charging cable, and the connector end of the charging cable should be periodically wiped with a clean dry cloth to remove accumulation of dirt and dust.
- Be careful not to damage the circuit board when removing the power entry knock-out.

2. Product Introduction





> 2.1. Product Appearance



1	Logo
2	Emergency Button Switch (When the button is pressed, the EV Charger will stop, then rotate the button pop-up reset.)
3	Electric leakage test button (For WPS connection, and leakage test.)
4	RFID
5	Type 2 socket
6	LED light

2. Product Introduction

> 2.2. Parameter table

Wallbox Models	BCP-A2N-P	BCP-B2N-P	BCP-AT2N-P	BCP-BT2N-P
				
Maximum Power	7.4KW		22KW	
Input voltage/Output voltage	AC230 1-Phase		AC400 3-Phase	
Input frequency	50Hz/60Hz			
Tethered/Socket	Tethered	Socket	Tethered	Socket
Meter	Metering Chip			
Display	LED Lights			
Frequency	50Hz/60Hz			
Rate Charging Current	6-32A			
Cable Length	5M/6M			
Standby Power Consumption	2W			
Operating Temperature	-25°C ~ 55°C			
Storage temperature	-40°C-85°C			
Operating Humidity	5%-95%			
IP Protection	IP65(Socket IP55)			
Safety Protection	Leakage Protection、Over Current Protection、Ground Protection、Over Voltage Protection、Under Voltage Protection、Contactor Adhesion Protection、Neutral and Live Wire Reverse Connection Protection、Over Temperature Protection、CP Signal Abnormal Protection、Lightning Protection			
Operating Altitude	<2000M			
Charger Dimension	Height: 380mm Width: 169mm Depth: 151/201mm			
Gross Weight	7KG/5KG			
Leakage Detection	TYPE A+DC6mA leakage sensor built-in			

2. Product Introduction

2.3. Features

- Connectivity: Ethernet and WIFI connection
- Opened Up Detection: Once the charger is opened up, the charger stop charging and make alarm.
- App Remotes: Remotely control the charger and have the charging history.
- Full Protection: For people's safety
- IP65 level protection
- Leakage Protection: with Type A sensor + DC6mA sensor
- Temperature Protection: Stop operating once over temperature.
- WPS WIFI Connection: Faster connection
- Operating Temperature: -25°C~+55°C

WIFI

Operating Frequency Range	2412 - 2484MHz
WI-FI Protocols	IEEE 802.11 b/g/n
Channels	13
TX Power	<20dbm
EIRP	0.459
TX bandwidth	20MHz/40MHz
Modulation type	OFDM & DSSS
Transmitting Duty Cycle	10%

BlueTooth BLE

Sensitivity @30.8% PER	-93 dbm
Co-channel C/I	+10db
RF Power Control Range	-12 ~ 9dbm

NFC

Modulation Type	ASK
Operating Frequency	13.56MHz
H-field strength	21.31 dBuA/m@3m distance
Antenna Type	Coil Antenna

2. Product Introduction

4G

Frequency Bands:	LTE-FDD: B1/B2/B3/B4/B5/B7/B8/B12/B13/B18/B19/B20/B25/B26/B28 LTE-TDD: B38/B39/B40/B41
Data:	LTE-FDD: Max. 150 Mbps (DL)/Max. 50 Mbps (UL) LTE-TDD: Max. 130 Mbps (DL)/Max. 30 Mbps (UL)
Output Power:	LTE-FDD: Class 3 (23 dBm ±2 dB) LTE-TDD: Class 3 (23 dBm ±2 dB)

3G

Frequency Bands:	WCDMA: B1/B2/B4/B5/B6/B8/B19
Data:	WCDMA: Max. 384 kbps (DL)/Max. 384 kbps (UL)
Output Power:	WCDMA: Class 3 (24 dBm +1/-3 dB)

2G

Frequency Bands:	GSM: B2/B3/B5/B8
Data:	EDGE: Max. 296 kbps (DL)/Max. 236.8 kbps (UL) GPRS: Max. 107 kbps (DL)/Max. 85.6 kbps (UL)
Output Power:	GSM850: Class 4 (33 dBm ±2 dB) GSM850 8-PSK: Class E2 (27 dBm ±3 dB)

2. Product Introduction

2.4. Protection Functions

With full protection to avoid all kinds of charging safety hazards, it will automatic power off after the vehicle is fully charged, to protect the car battery and prolong the working life.



2. Product Introduction



Warning

- ⚠ Normally, the earth wire should be properly connected, otherwise the EV charger will not work.
- ⚠ For situation where there is no earth connection, in order to enable the EV Charger to operate, it can be set via APP to turn off the earth detection and it will work, but it will reduce to the leakage protection safety level.
- ⚠ This BCP series AC EV charger must be grounded via a permanent electrical system or equipment grounding conductor.
- ⚠ Before installing an AC EV charger, please confirm the type of grid connection available. If you are unsure of the type of connection available on the service panel, please consult an electrician or contact ZJBENY for assistance.
- ⚠ Note: Please consult your local electrician or refer to your local code in order to choose the proper wire for the AC EV charger current.

3. Installation Instructions

3.1. Installation Considerations

- Note: Throughout the manual, "conduit" is used as the standard term for the protective tubing that houses the service wiring. In regions where conduit is not used (Europe for example), a cable comprised of service wiring enclosed in a protective jacket may be substituted for conduit if allowed by local regulations.
- Here are some additional guidelines
- Conduit needs to be metal and flame retardant.
- Use an appropriate circuit breaker.
- To keep the housing weatherproof, use cable glands.

3.2. Minimum Installation Requirements

Installation of the wall charger requires that you:

- Calculate the existing electrical load to determine the maximum operating current.
- Calculate the distance to ensure minimal voltage drop.
- Obtain any necessary permits from the local authority that has jurisdiction and confirm that the follow-up inspection has been scheduled by an electrician after the installation is complete.
- Use only copper conductors.
- Use copper wire that meets the specifications of local wiring regulations. The selected cable must be capable of withstanding continuous loads of up to 40A at all times. The selected circuit protection device must incorporate an appropriate wall-mounted residual current device (RCD) and corresponding electrical load over current protection.

3. Installation Instructions

3.3. Position

- Ensure that the parking position is within range of the charging cable.
- There is enough clearance for the charging cable to wrap around and the charging handle can be comfortably positioned on the side of base.
- If installed in an enclosed garage, choose to install on the side of the EV charger slot.
- For outdoor installations, waterproof protection is recommended but not mandatory.
- Install in a well-ventilated space. Avoid installation in enclosed boxes or close to high power appliances.

3.4. Height

- Maximum height (indoor and outdoor): 60 inches (1.5 m)
- Recommended height: 47 in (~1.2 m)
- Minimum outdoor height: 24 in (0.6 m)
- Minimum interior height: 18 inches (0.45 m)

3.5. Power Supply

230V single-phase power supply

- For single-phase EV charger, a single-phase wire (L), Neutral and earth wire must be connected. The phase voltage between the Line and Neutral wires should be 230V.
- For 3-phase EV charger, connect the single phase wire (L1), the neutral wire and the earth wire do not connect the other phase wires (L2 or L3). The phase voltage between the line and neutral wires should be 230V.

400V three-phase power supply with neutral line

- If three phases are applied, all three phases (L1, L2 and L3) and the neutral line should be connected to each other and the voltage of each phase to the neutral line should be 230V.

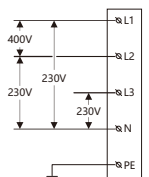
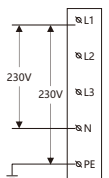
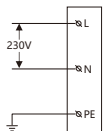

3. Installation Instructions

> 3.6. Accessories List

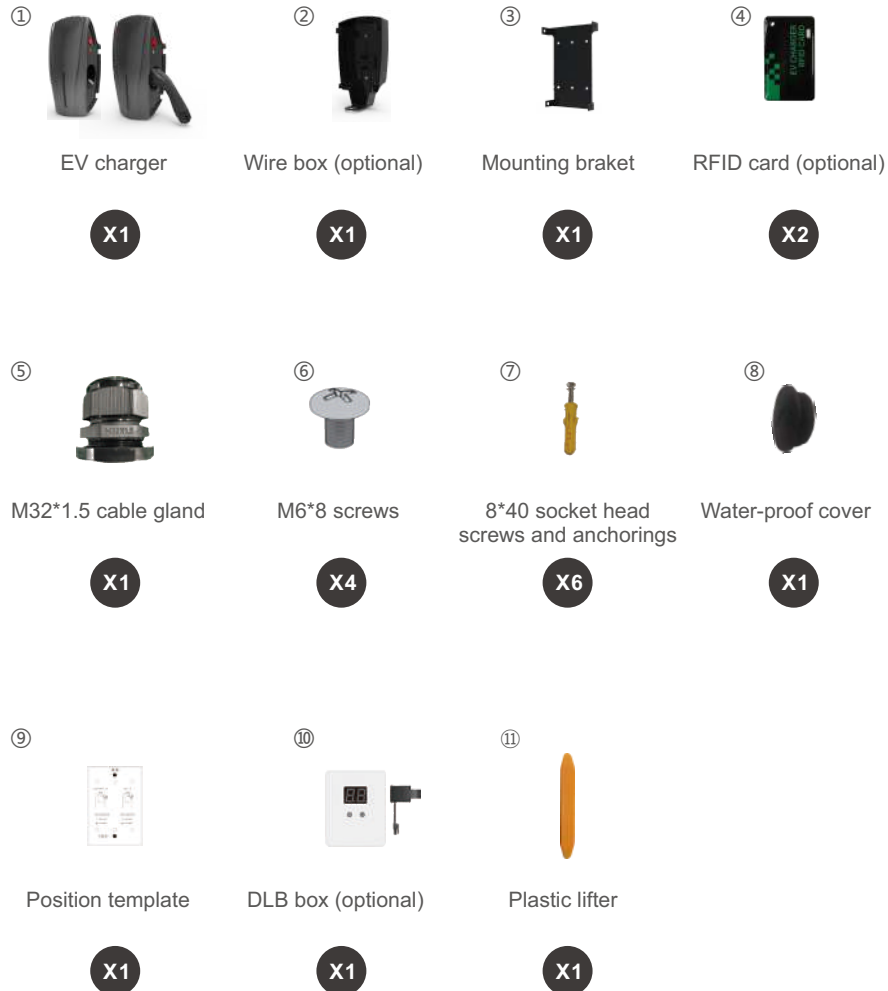

Note: Card type supported by RFID: RF card ISO14443 Type A, MIFARE® ONE (MF1) card, with the read-write frequency of 13.56MHz±7K.

3. Installation Instructions

> 3.7. Installation Step

> 3.7.1. Step-by-step Installation Instructions (bottom entry wiring)

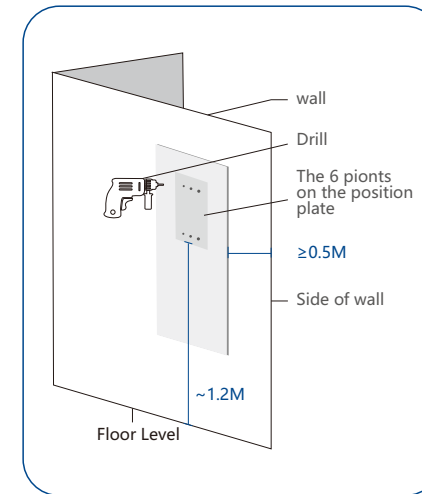

Step 1

Position

The bottom of the ⑨positioning plate is 1.2 m away (recommended), if the EV charger is installed close to the edge of the wall, the positioning plate should be more than 0.5 m away from the edge of the wall.

Drilling pilot holes

Drilling the holes according to the instruction on the Position template for different installation and wiring ways.

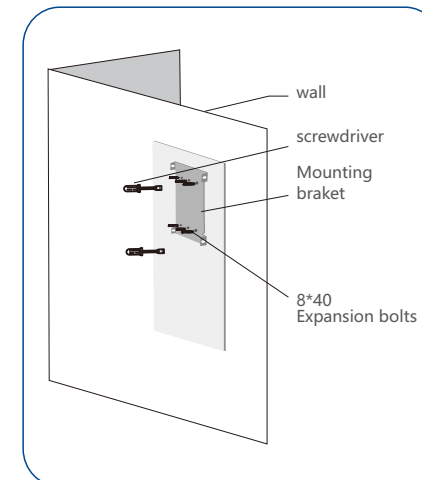

Step 2

Install the Mounting bracket

Put the 8*40 Socket head screws' anchoring into the holes, and use the screw driver make the 6pcs 8*40 Socket head screws to fix the Mounting bracket on the wall .

3. Installation Instructions

> 3.7.1. Step-by-step Installation Instructions (bottom entry wiring)

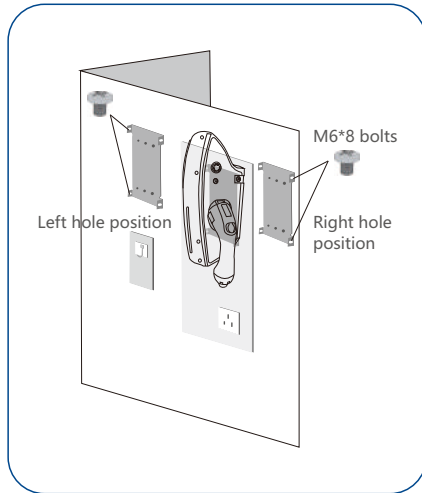

Step 3

Install the EV Charger to the mounting plate

Align the side hole of EV charger to the panel's side holes.

Installation

Use the 4pcs M6*8 screws to fix the EV charger to the mounting plate as picture shows (Screws torque 1.5NM-2.0NM).

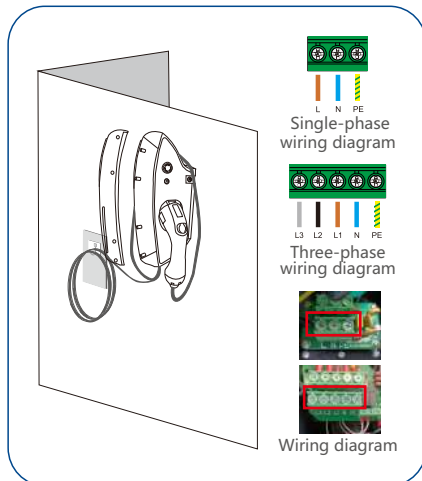

Note: The torque applied to the screws should be 1.8N-m to 2.2N-m

Step 4

Wiring

Note: Consult with your local electrician or refer to your local code for proper wire sizing appropriate for the currents in your EV Charger.

Note: It is the installer's responsibility to identify whether additional grounding is required to ensure that local regulations are met. Grounding must be installed at the power source and not at the cable entry to the EV Charger.

As the picture at left shows, use the screwdriver loosening the screws on the EV charger cover. Wire the cable to the according terminal.

3. Installation Instructions

> 3.7.2. Step-by-step Installation Instructions (rear entry wiring)

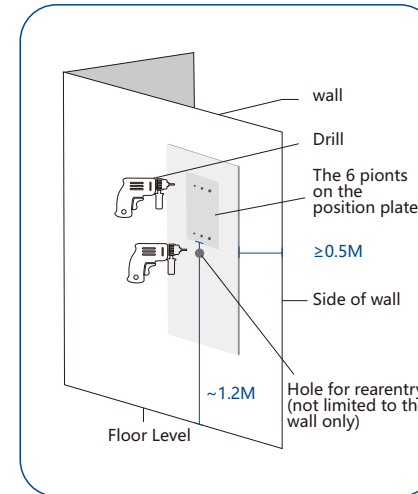

Step 1

Position

The bottom of the ⑨positioning plate is 1.2 m away (recommended), if the EV charger is installed close to the edge of the wall, the positioning plate should be more than 0.5 m away from the edge of the wall.

Drilling pilot holes

Drilling the holes according to the instruction on the Position template for different installation and wiring ways.

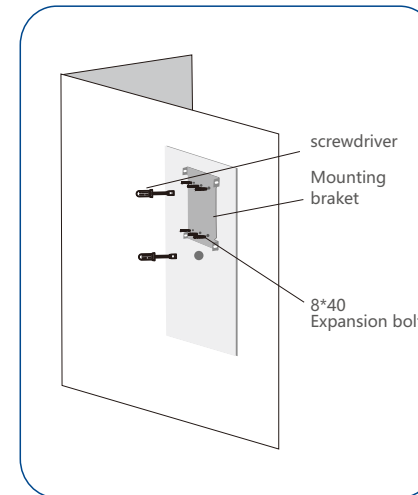

Step 2

Install the Mounting bracket.

Put the 8*40 socket head screws' anchoring into the holes, and use the screw driver make the 6pcs 8*40 Socket head screws to fix the mounting bracket on the wall .

3. Installation Instructions

> 3.7.2. Step-by-step Installation Instructions (rear entry wiring)

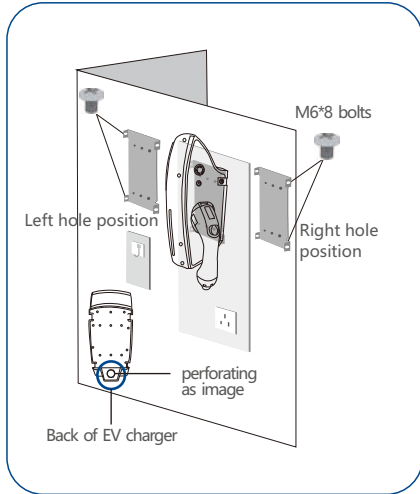

Step 3

Install the EV Charger to the mounting plate.

Find the hole for cut out on the back of EV charger.

Use the 4pcs M6*8 screws to fix the EV charger to the mounting plate as picture shows (Screws torque 1.5NM-2.0NM).

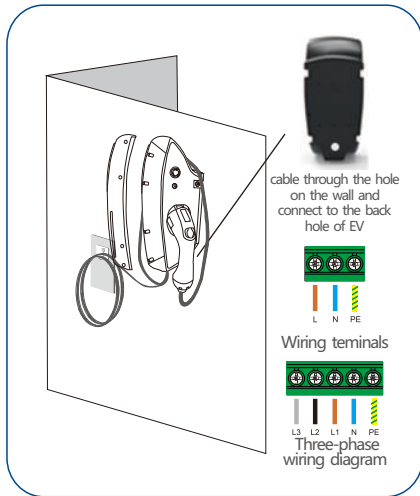

Step 4

Wiring

Note: Consult with your local electrician or refer to your local code for proper wire sizing appropriate for the currents in your EV Charger.

Note: It is the installer's responsibility to identify whether additional grounding is required to ensure that local regulations are met. Grounding must be installed at the power source and not at the cable entry to the EV Charger.

As the picture at left shows, use the screwdriver loosening the screws on the EV charger cover. Wire the cable to the according terminal.

Note: The torque applied to the screws should be 1.8N-m to 2.2N-m

3. Installation Instructions

> 3.7.3. Step-by-step Installation Instructions (top entry wiring)

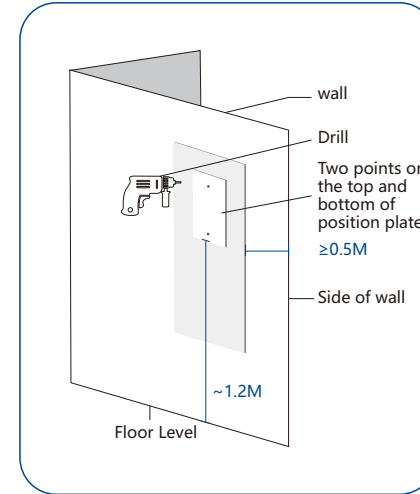

Step 1

Position

The bottom of the ⑨ positioning plate is 1.2 m away (recommended), if the EV charger is installed close to the edge of the wall, the positioning plate should be more than 0.5 m away from the edge of the wall.

Drilling pilot holes

Drilling the holes according to the instruction on the Position template for different installation and wiring ways.

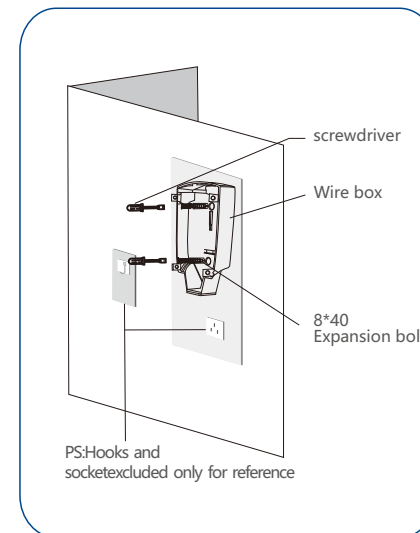

Step 2

Fix the wire box

Put the 8*40 flat head screws anchoring into the holes and use the screw driver make the 2pcs 8*40 flat head screws to fix the Wire box Mounting Template on the wall.

3. Installation Instructions

> 3.7.3. Step-by-step Installation Instructions (top entry wiring)

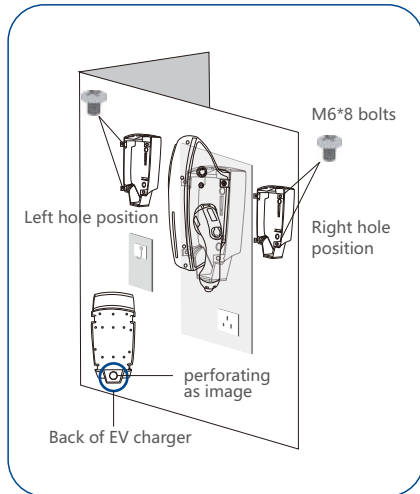

Step 3

Cut out on the back of the EV charger.

Find the hole for cut out on the back of EV charger.

Use the 4pcs M6*8 screws to fix the EV charger to the mounting plate as picture shows (Screws torque 1.5NM-2.0NM).

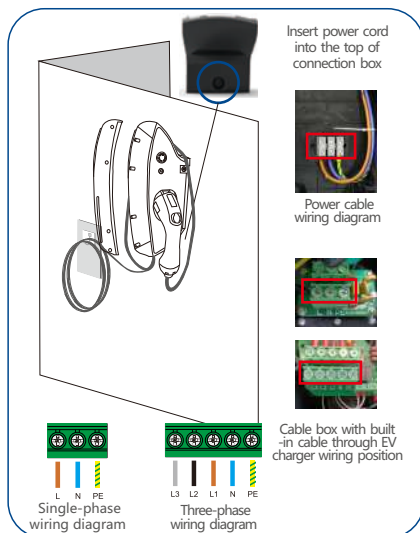

Step 4

Wiring

Note: Consult with your local electrician or refer to your local code for proper wire sizing appropriate for the currents in your EV Charger.

Note: It is the installer's responsibility to identify whether additional grounding is required to ensure that local regulations are met. Grounding must be installed at the power source and not at the cable entry to the EV Charger.

As the picture at left shows, use the screwdriver loosening the screws on the EV charger cover. Wire the cable to the according terminal.

Note: The torque applied to the screws should be 1.8N-m to 2.2N-m

3. Installation Instructions

> 3.7.4. External Meter Installation

⚠ Warning

- Do not connect the power cord before reading and fully understanding all the concepts introduced in this section. If you are not sure whether the type of power supply on the repair panel is available, please consult an electrician for assistance.
- Be careful of electric shock! Before use, use a voltmeter to confirm that there is no voltage on the power supply line or terminal to ensure that the power has been cut off.
- Disconnect the power supply at home, and find the neutral wire and the live wire at the entrance to the house.
- According to the wiring figure, the live wire and the neutral wire are respectively connected to the power grid through cables that support a current of more than 32A, so that the connection between the power meter and the power grid is completed.
- According to the wiring figure, connect the live wire and neutral wire to the interfaces reserved in the charger respectively through the cables that support more than 32A, so that the meter is connected.
- The AB interfaces on the meter needs to be connected to the AB interfaces in the charger PCB Via a cable that supports 485 communication.
- The ground wire of the grid needs to be connected to the ground wire interface which is reserved in charger.
- The meter has been configured to fit the charger by default, please do not change the configuration. Please contact us for technology support if you are going to install meters are not from us.

3. Installation Instructions

> 3.7.4. External Meter Installation

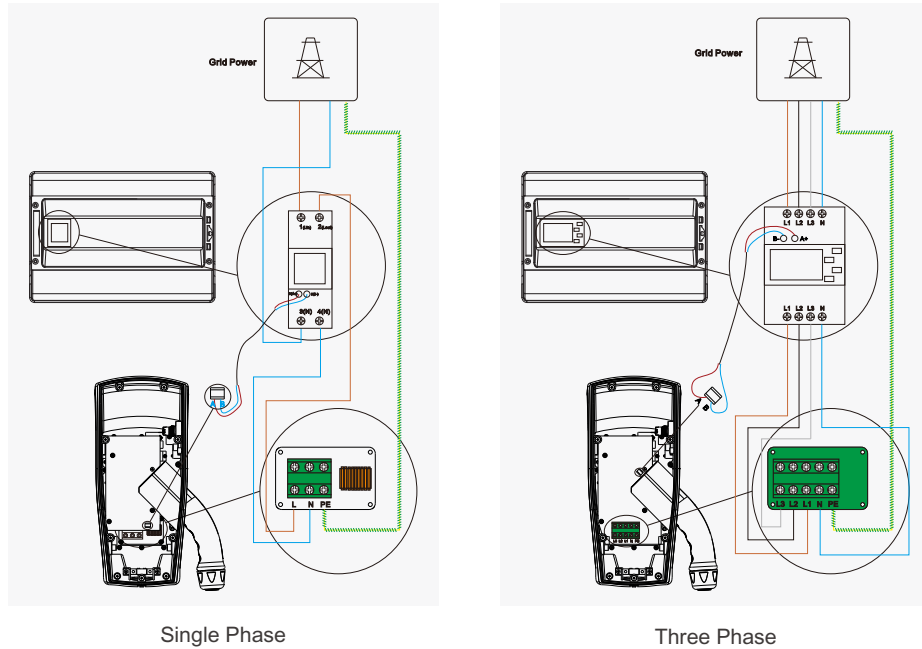

3. Installation Instructions

> 3.7.5. Set the Operating Current

- After installation, users can set the maximum operating current of the EV charger in the APP, Please refer to APP manual for details.

> 3.7.6. Reinstall the Sealing Cover and Turn on Power



> 3.8 SIM Card Installation

- Note: If you need to use 4G mode, please install a Micro SIM card

4. Operating instructions

4.1. Buttons On harger

- Emergency stop button

Press	Stop the charging
Button ejecting	Fixing faults
Button ejected	In operating

- Test button

Press	Leakage test
Long Press	WPS mode works, search for WPS and pair.

- Rest button on PCB Long press for 5s Reset the charger password (Wi-Fi Ap Password and OCPP configuration Password)
- To restore the charger to be default settings, after press the emergency stop button and long press the reset button for 20S to achieve.
- Press the emergency button and the test button while powering on again the EV charge. Then start the OCPP configuration process.

4. Operating instructions

4.2. Buzzer





Swipe the RFID card to start the authentication successfully	One Short Beep
Swipe the RFID card to stop the authentication successfully	Two Short Beeps
RFID card authentication failed	Five Short Beeps
Enter server configuration mode	One Long Beep
Server parameters are configured successfully	One Long Beep
Server parameter configuration failed	Two Short Beeps
Leakage test in progress	One Long Beep

4.3. Dynamic Load Balancing Kit

- The Dynamic Load Balancing Kit is suitable for home charging use.
Connect the DLB kit with the charger, to active the DLB function automatic.
Disconnect the DLB kit with the charger, to off-line the DLB function automatic.

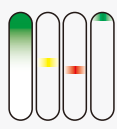
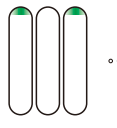
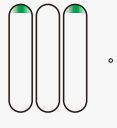
4. Operating instructions



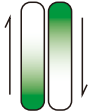
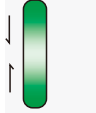
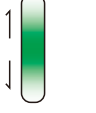
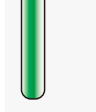
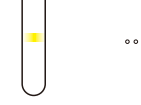

4.4. LED Lights Display

Normal Status				
LED Behavior	LED Status	Status Description	Potential Cause	Solution
	Lights OFF	No power supply	No power	Check the power source
	The green lights light up in sequence from top to bottom, then the yellow and red lights light up in sequence until the first green light blinks	Charger Power ON self test		
	The first green light fast blinking (ON for 0.25 seconds, OFF for 0.25 seconds)	Enter WPS configuration	In WPS configuration status	Recheck the configuration
	The first green light slow blinking (ON for 1 second, OFF for 1 second)	Network is not connected	Wi-Fi connection failure or wrong password	1.5G or WPA 2_Enterprise is not available for charger 2.Ensure password is correct 3.Restart the APP
	The first green light breathing magenta	Standby		
	The first green and the last green lights slow blinking. (ON for 1 second, OFF for 1 second)	The charger is reserved		
	The 1-6 green lights ON, brightness decreases from top to bottom	Charger authorized, waiting for the Charging Connector plug in		



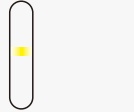
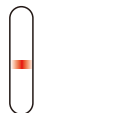

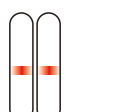

4. Operating instructions

Normal Status				
LED Behavior	LED Status	Status Description	Potential Cause	Solution
	Green lights up and down	The Charging Connector is plugged in, waiting for RFID card authentication		
	Green lights end in the middle	Waiting for the car start to charge		
	Green lights extend from the middle to the ends	Charging		
	All green lights ON	Charging finished		
	Yellow lights flashing	Charger is remotely disabled or not registered	Charger is not configured	Configure the charger

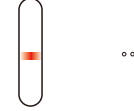
4. Operating instructions

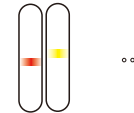
Fault Status				
LED Behavior	LED Status	Status Description	Potential Cause	Solution
	All lights strobe (4 times per second)	Contact failure	Contact adhesion or tripping	Check whether the vehicle charging module is normal
	Yellow lights ON	Emergency stop protection	Emergency stop button is pressed	Rotate the emergency stop button Pop-up reset
	Red lights ON	Grounding abnormality	The ground wire is not wired or the neutral wire is reversed	Check whether the grid connection and charger wiring is correct
	Red light once	Over Voltage	Power supply has short circuit or unstable	1.Check the power supply 2.Check the wire of power supply
	Red light twice	Under Voltage	Power supply voltage is insufficient	1.Check the power supply 2.Check the wire of power supply
	Red light thrice	Leakage fault	Leakage happens	1.Reset with emergency stop button 2.Check the charger connector or vehicle for leakage

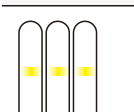
4. Operating instructions

Fault Status				
LED Behavior	LED Status	Status Description	Potential Cause	Solution
	Red light flashes continuously (Once per second)	Over current	Short circuit may happen	Call for professional repair
	Red light flashes (Quartic per second)	Over temperature alarm	High temperature	1.Wait for charger cooling 2.Ensure the wiring of charger terminal is not losing
	Alternating red and yellow continuously Red for 0.5 seconds followed by yellow for 0.5 seconds	Abnormal CP signal	The connection between the charger and the vehicle is loose	1.Check if the connector is with water leakage in 2.Ensure the connector is matched with EV
	Red and yellow lights flash once	Abnormal CC signal	The connection between the charger and the vehicle is loose	Check whether the charger connector is firmly inserted
	Yellow light ON triple	LED board is offline	LED board is fault or losing	Open the charger cover and check whether the light board cable is connected correctly and firmly
	Yellow light ON once, red light ON once	DLB is offline	The DLB connection is loose	Check the connection between DLB box and charger
	Yellow light ON once, red light ON twice	DLB abnormal	The connection between the DLB box and the CT is loose or the CT is not clamped	1.Check the CT of the DLB box is in the correct position 2.Check whether the DLB box CT is firmly clamped 3.Check if the phase sequence of the DLB box CT is correct 4.Check if the connection between the DLB box CT and the DLB box is firm

4. Operating instructions

> 4.5. Firmware Update via OCPP Server

The server sends a firmware upgrade command to the EV charger in the background, and when the set time comes, the firmware starts to download.

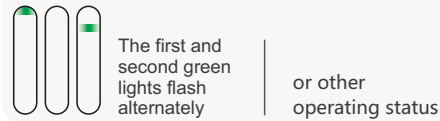

Download firmware

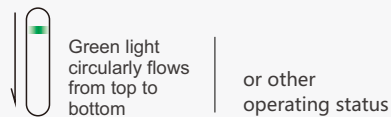

If the EV charger is charging, install the firmware after the charging is completed.

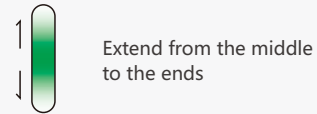

Install firmware



End charging

All green lights on

The update is complete, ready to reconnect to the network

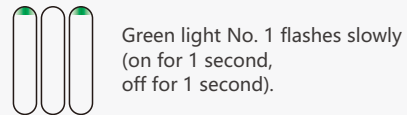

Network connection is successful.



5. Warranty

> 5. Warranty

In order to ensure the normal service life of charging piles and reduce the risks in use, maintenance must be done within the specified time by professionals with accredited safety maintenance tools.

- Three-year free warranty is provided for any damage or malfunction caused by quality problems from the date of production of the charger.
- Damage caused by operation failure, natural force majeure, incorrect installation or instructions for use is not covered.
- Repair can only be performed by professionals. If any problem occurs during installation or use, contact your dealer first.

> 6. Manufacturer self-declaration

1. In order to improve the stability of the charger, BENY will provide software updates for at least three years from the date of manufacture of the charger.
2. The charger will not collect and save users' sensitive personal data, such as payment information, timestamped location data, audio input stream or biometric data.
3. The manufacturer will not collect telemetry data of the charger through remote service.